

ABS Plus | Adjustable-height disposable formwork system for filling applications

ABS Plus is an adjustable-height disposable concrete formwork system made of recycled plastic. The system is also called “void formers”, “permanent formwork” or “single-use formwork”. It creates reinforced concrete raised floors up to 300 cm, thus providing a light, fast, easy and economical filling in any structure.

ABS Plus Disposable Formwork System consists of four different elements:

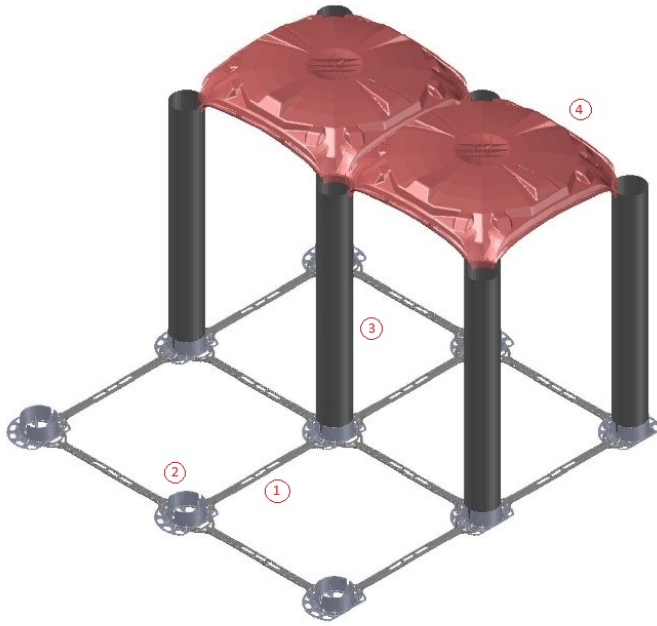

1- ABS Plus - Spacer

(min. 2, max. 4 pcs per m², depending on the project)

2- ABS Plus - Base

(2 pcs/m², Ø125 mm, H 2,5 cm)

3- PVC Pipe Ø125 mm

(cut to the heights required by the project, 2 pcs/m²)

4- ABS Plus - H15 Dome

(2 pcs/m²)

To accommodate project-specific heights, the PVC pipes are cut to specification at factory before delivery. Alternatively, standard-length pipes can be cut on-site by the customer fitting exact heights.

Unlike similar systems, the ABS Plus system consists of 2 legs per m², which, in addition to the advantages listed below, provides additional ease of application and significant cost savings on concrete and steel.

ABS Plus system can be used for any sort of lightweight filling application. Uses include sunken slab fillings, landscape fillings to create a hard surface, inverted beam fillings, fillings between foundation footings, carpark ramps, pool decks, elevator/staircase hallway fillings and crawlspace construction.



Advantages

- **The lightest solution to any filling problem:** Regardless of the height, only the weight of the topping concrete is added to the structure. In addition, the arch-dome shape of the formwork reduces the required thickness of the topping concrete.
- **Unmatched logistical advantage:** The design makes the system components stackable, nesting in each other, providing enormous space efficiency. At a sample height of 100 cm, 1 truck of disposable formwork equivalents 50 trucks of alternative filling material!
- **Very high load-bearing capacity:** At a sample height of 100 cm and with only 5 cm of topping concrete, the live load-bearing capacity is 55 kN/m².
- **Reduced construction time:** Construction activities on upper floors can proceed without having to wait for the filling application on lower floors, as the filling application can be done anytime, saving very valuable construction time.
- **Void space creation:** The void space that gets created under the domes has a net width of 59 cm between Ø125 mm columns. This means that any sort of electrical or mechanical installation can be passed through it either before or after construction.
- **Fast and easy installation:** Installation can be as fast as 20 m²/hour and requires no skilled labor.
- **Ramp construction:** The PVC pipes can be cut at any size needed to create a ramp.
- **Continuous concrete surface:** Any sort of covering (epoxy paint, wood flooring, asphalt etc.) can be applied on the concrete surface very easily. Similarly, separator walls can be installed directly on the surface.
- **Heat and sound insulation:** The void spaces can provide a degree of heat and sound insulation.
- **Radon gas and damp barrier:** If used above foundations and properly ventilated, the system is the most economical and safest way to remove radon gas, humidity and dampness from living quarters.
- **Environmental value:** Because the formworks are made of recycled PP, they help to gain considerable LEED certificate points.



Technical Data

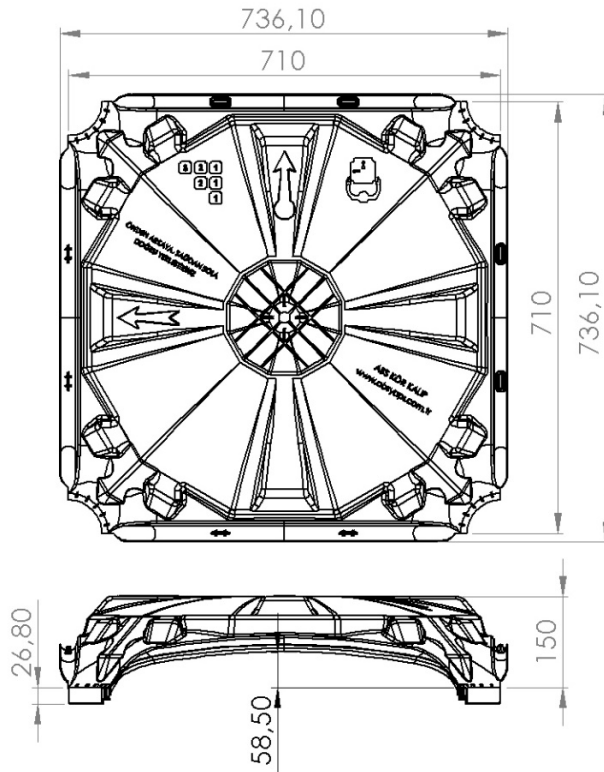

ABS Plus - H15 Dome (2 pcs = 1 m²)

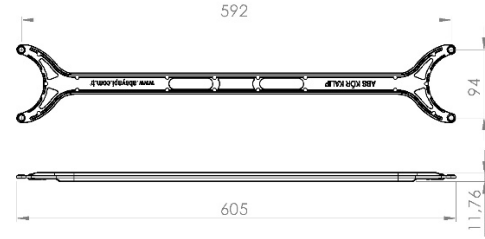

ABS Plus - Spacer
(max. 4 pcs = 1 m²)

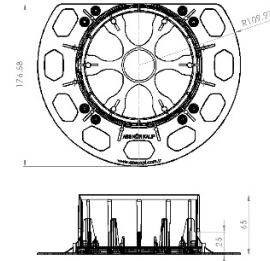

ABS Plus - Base
(2 pcs = 1 m², Ø125)

Dome size	71 x 71	cm, 2 domes per m ²
Dome height	15	cm, net height w/o leg connections
Base height	2,50	cm, 2 bases per m ²
Leg diameter	Ø125	cm, 2 legs per m ²
Leg height	variable	cm, depending on requirement
Number of spacers needed	max 4	lower than 50 cm heights may not require any spacer at all, however all four spacers are need for heights more than 120 cm
Material	dome, base and spacer recycled PP, leg recycled PVC	
Pallet dimensions (dome)	75 x 150 x 265	cm
Pieces per pallet (dome)	180	pieces
Area covered per pallet (dome)	90	m ²
Pallet weight (dome)	361	kg
Application speed	20	m ² /man-hour on a rectangular area

Formulas

h = height in cm of the topping concrete calculated separately depending on the live loads needed

H = total height of the ABS Plus system in cm before concrete casting

Leg height in cm = H - 15 cm - 2,5 cm

Concrete consumption in m³/m² = h/100 + 0,03554 + [(H - 15)/100 x 0,02453]

Use of Spacers

When used in all directions, a maximum 4 spacer are required per m². However, with respect to the application geometry, it is also possible to connect all the spacers in one direction and to skip 2 or 3 in the other 90-degree direction.

At less than 100 cm heights spacers can be completely omitted except at starting points or around columns etc. assuming a standard wet concrete pressure will be applied. Also, in ramp applications, the spacers cannot be used in the direction of the inclination.

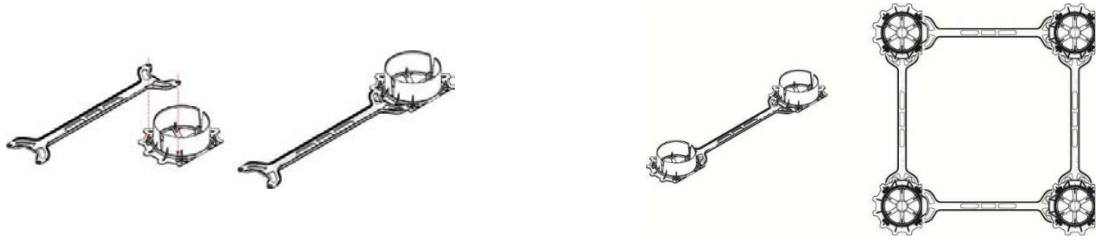

In case the applicable area surface is wide, leveled, in rectangular shape and clean of any debris, spacers may be skipped by 2 or 3 in one direction.

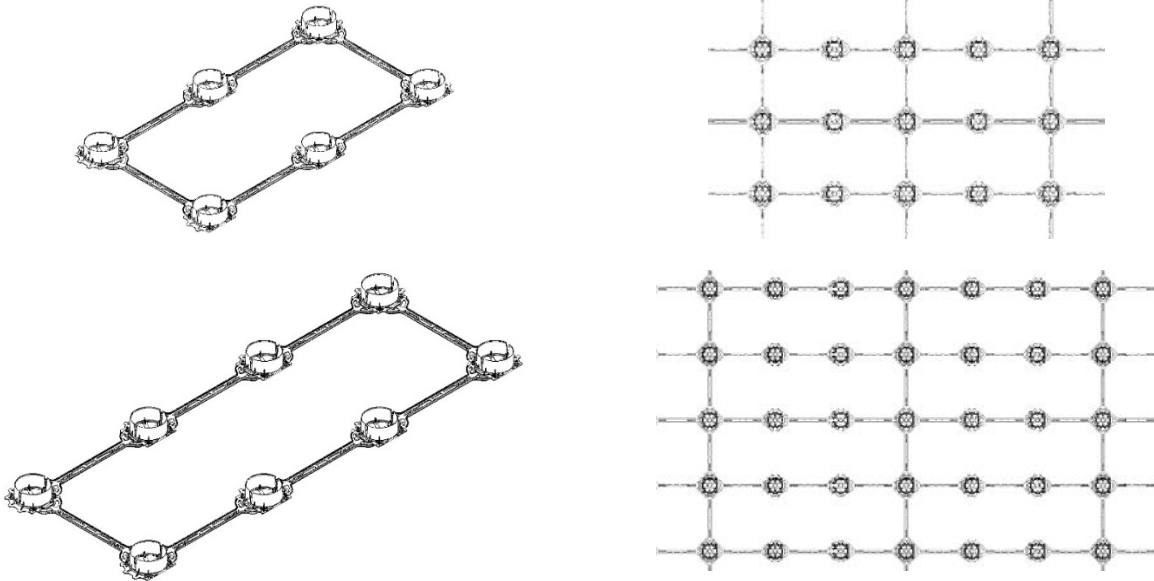

Side Finishes

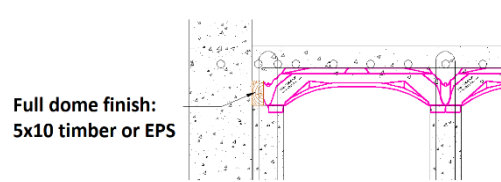
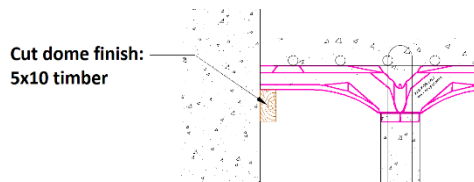

Technical Specifications

Please refer to the document “[Technical Specifications | Creating Reinforced Concrete Raised Floors Using Disposable Formworks](#)” and “[Installation Manual](#)” for further detailed instructions about general application guidelines.

