

**“ABS Plus Disposable Formwork System” developed by  
ABS BUILDING MATERIALS IND. TRADE CO. LTD.**

## **TECHNICAL REPORT**



## **OF PLASTIC DISPOSABLE FORMWORKS**

*This report has been prepared in accordance with the Regulations of ITU Revolving Fund Enterprise.*

***Prepared by:***

**Assoc. Prof. Dr. Beyza TAŞKIN**

**Asst. Prof. Dr. Burcu GÜNEŞ**

*İTÜ Civil Engineering Faculty, Civil Engineering Department,  
RC Structures and Structural Analysis Work Group Lecturers*

**June, 2018**

Respectfully submitted to **ABS Building Materials**

Reference: Your application on 18.05.2018 with 409861 registration number

## 1. SUBJECT

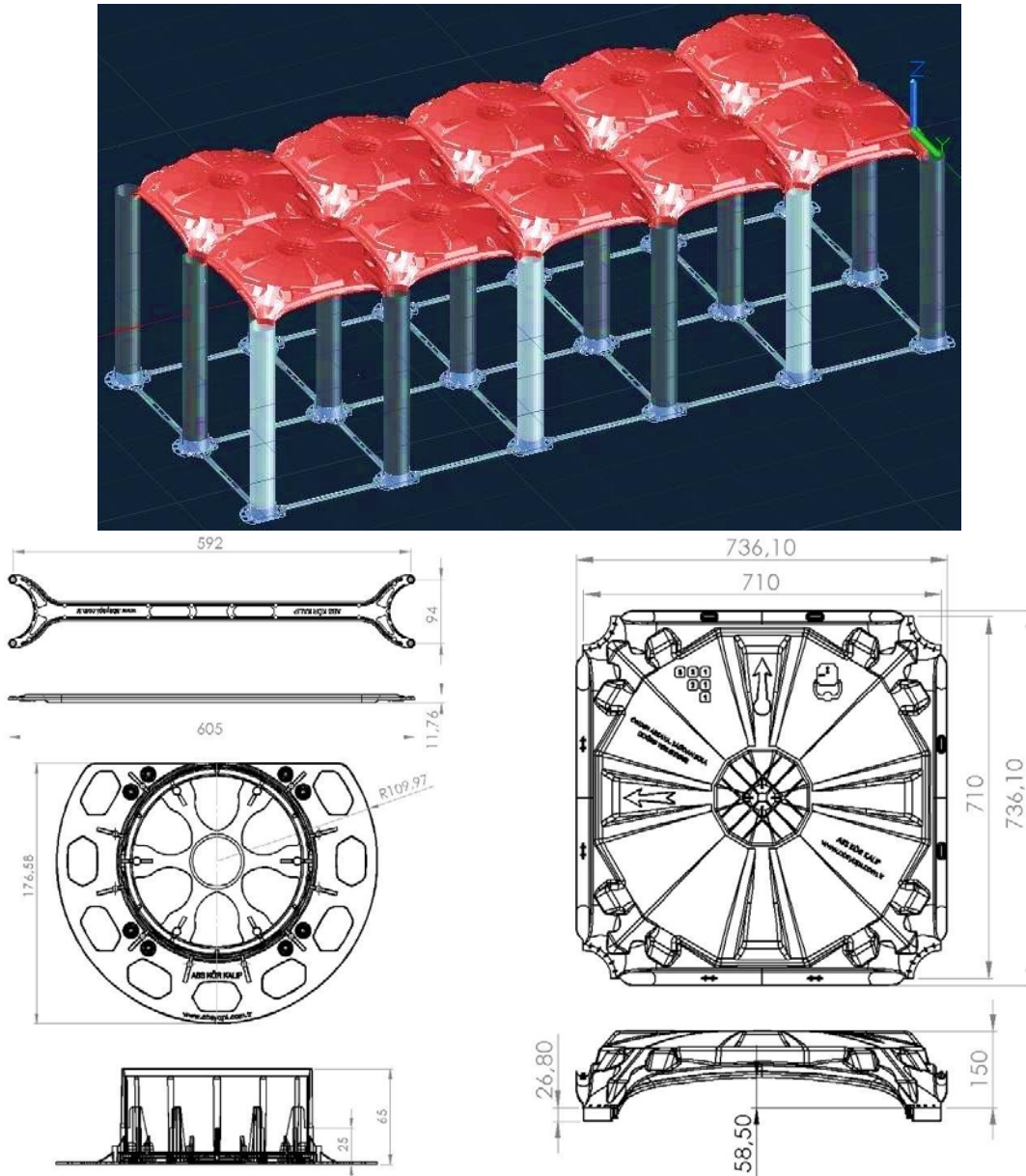
ABS Building Materials Ind. Trade. Co. Ltd. has made a request to Istanbul Technical University, Civil Engineering Faculty Deanery for a technical report in order to analyze the capacity and behavior of the plastic modular formworks “ABS Plus Disposable Formwork System” developed by themselves.

This report has been prepared on the approval of Istanbul Technical University Civil Engineering Faculty Deanery on **18.05.2018** with the number **409861** regarding the documents submitted to our review.

## 2. CHARACTERISTICS OF PLASTIC DISPOSABLE FORMWORKS

ABS Plus Disposable Formwork System, a disposable, domestic production, consists of the elements shown in Figure 1 and can be used to construct systems such as concrete raised floors, ramps, graded surfaces, underground storage tanks, accessible galleries and ventilation shafts. As can be seen in the figure, axis of the system is composed of tube shaped (circular cross-section) vertical bearings made of polyvinyl chloride (PVC) getting fixed on bases that are aligned by spacers and on each four columns, plastic disposable formwork dome made of polypropylene (PP) is supported in a way that it covers 1/4 of the circumference of the column below.

Plastic disposable formwork system consists of a main dome shaped element that has a size of 710mmx710mm horizontally and 150mm vertically. Due to its arched structure and square form, it enables a steady and symmetric load transfer of the slab to the columns. The columns have a standard diameter of 125 mm, and each dome is placed as 1/4 of the circle length on the top edge of each column, and thus four domes are supported by a single column. Due to the dome geometry, a regular “column cap” occurs around the structural bearing area that bears the punching loads. Through the use of standard base and spacers at the bottom of the columns, the columns are aligned perfectly in both x and y axis, preventing the system from an axial run-out.



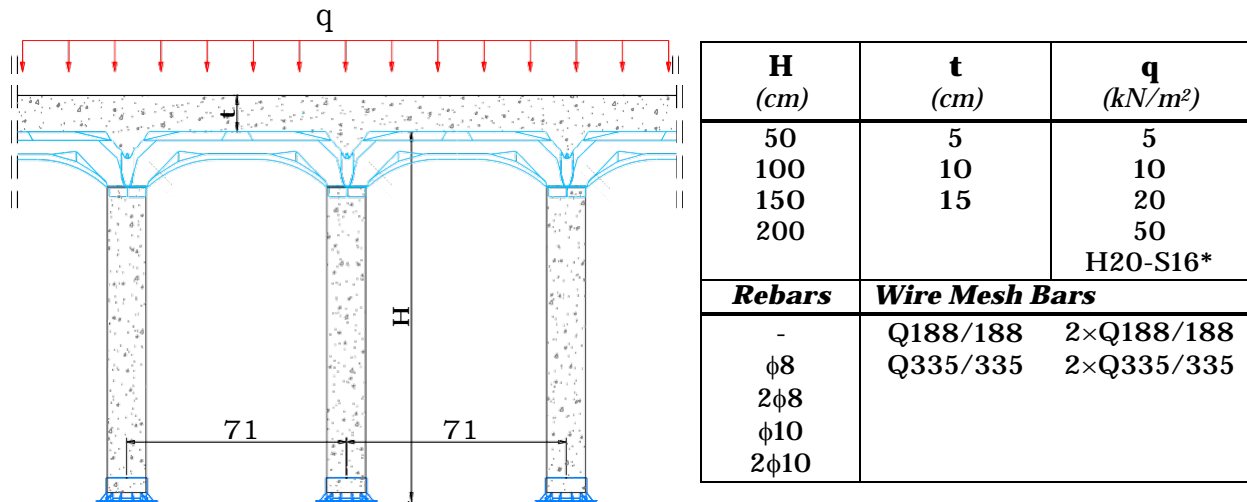
**Figure 1:** Components of ABS Plus Disposable Formwork System: 3D view (top); spacer and base (left); plan view and section of the dome (right)

Installation of ABS Plus Disposable Formwork System starts with mounting the bases and spacers on the lean concrete or base slab etc. that already exists. Plastic tubes that will form the columns are assembled onto the bases. Plastic tubes have a standard diameter of **125 mm**. Length of the tubes may be adjusted previously or on site according to need. Standard manufacturing length of the tubes is 3000 mm. Following the tube assembly and placing the domes, installation process is finished. Later on, reinforcing steel bars that are calculated depending on the slab thickness, live loads and system height are placed in the tubes and on top of the domes and the structure gets ready for concrete casting.

### 3. PARAMETRIC ANALYSES

Numerous parametric analyses were done to determine the structural behavior and capacity requirements of ABS Plus Disposable Formwork System under vertical loads. In these analyses, additional soil stress and behavior under the earthquake loads when the system is placed on the lean concrete or base slab were not taken into consideration; yet, basically a guideline was created showing the design and safety level for a specific height, slab thickness, amount of live load and certain configurations of rebar layouts.

Configurations analyzed on ABS Plus Disposable Formwork System are shown in Figure 2 schematically and numerical values are summarized as well.



\* For H20-S16-44 truck load design, front axle value is considered to be 40 kN; central and rear axle values are considered to be 160 kN (Figure 3). Braking force is assumed to be 25% of axle weights.

Figure 2: System configurations and numerical values of the characteristic parameters

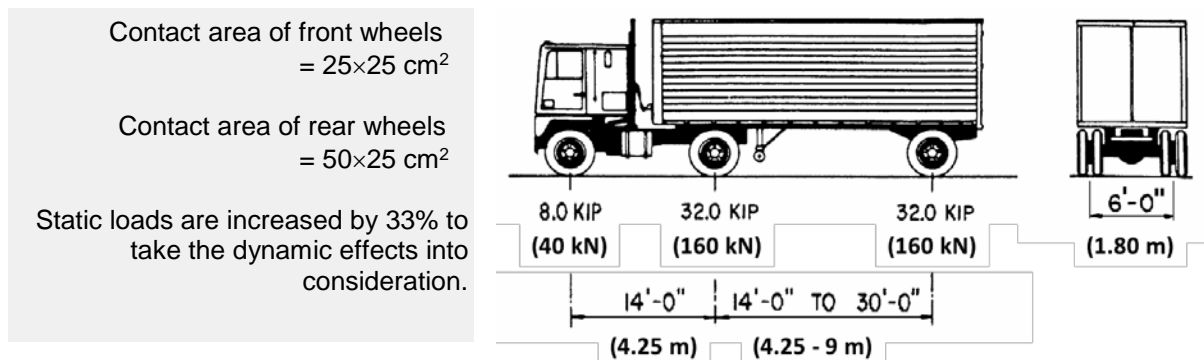
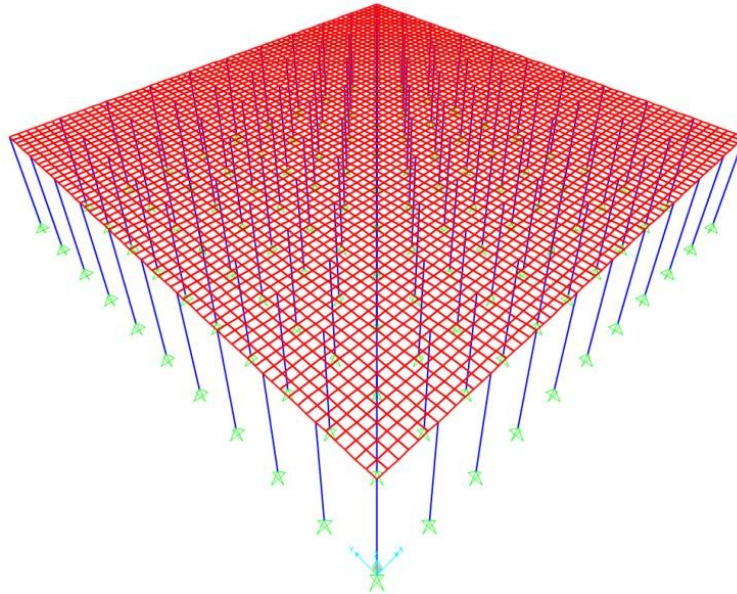


Figure 3: Design of truck loads

### 3-a. Structural Modelling

In order to analyze the behavior of the systems with different ABS Plus Disposable Formwork System configurations under vertical loads, a **7.1m $\times$ 7.1m** slab system composed of 10 units in both axis directions was created using SAP2000 computer program. Two models were created separately for **C25** and **C30** concrete classes, 375 different models were set considering the various structural parameters in Figure 2. For example, Figure 4 shows the 3D analytic model prepared with C25 concrete class, H=150 cm system height and t=10 cm slab thickness. Since the columns are placed freely on the bases, bottom edges are defined as hinged support and each slab box are divided into 6x6 finite element.

**Figure 4:** SAP2000 analytic model for ABS Plus Disposable Formwork System



In the system, unit weight of the columns with a standard cross section and  $\varnothing 125$  mm diameter was calculated as **0,307 kN/m/piece** taking the concrete apparent specific gravity  $\gamma_c = 25 \text{ kN/m}^3$ . Therefore, for a system height of 50 cm, 100 cm, 150 cm and 200 cm, weight of a single column is 0.153 kN; 0.307 kN; 0.460 kN and 0.614 kN, respectively. Self-weight of the arches occurring between domes and caps on top of the columns was calculated to be  $\approx 1.70 \text{ kN/m}^2$  based on the system geometry. Adding  $1.25 \text{ kN/m}^2$  self-weight to the standard loads for 5 cm slab thickness,  $2.50 \text{ kN/m}^2$  self-weight for 10cm slab thickness and  $3.75 \text{ kN/m}^2$  self-weight for 15 cm slab thickness, permanent loads acting on the system (g) for different slab thicknesses may be calculated.

Similarly, taking the different live loads (q) given in Figure 2 into account, total design load (p) was calculated in accordance with TS-500 regulations by the help of the load consolidation formula given below:

$$p = 1.4xg + 1.6xq$$

Among the live loads, to specifically determine the truck load effect, a longer system that can contain a truck was modelled as seen in Figure 5.

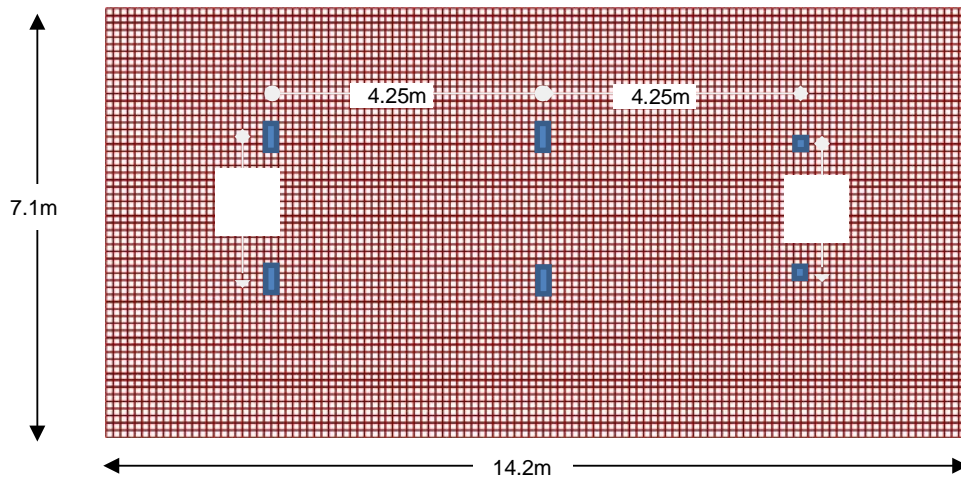


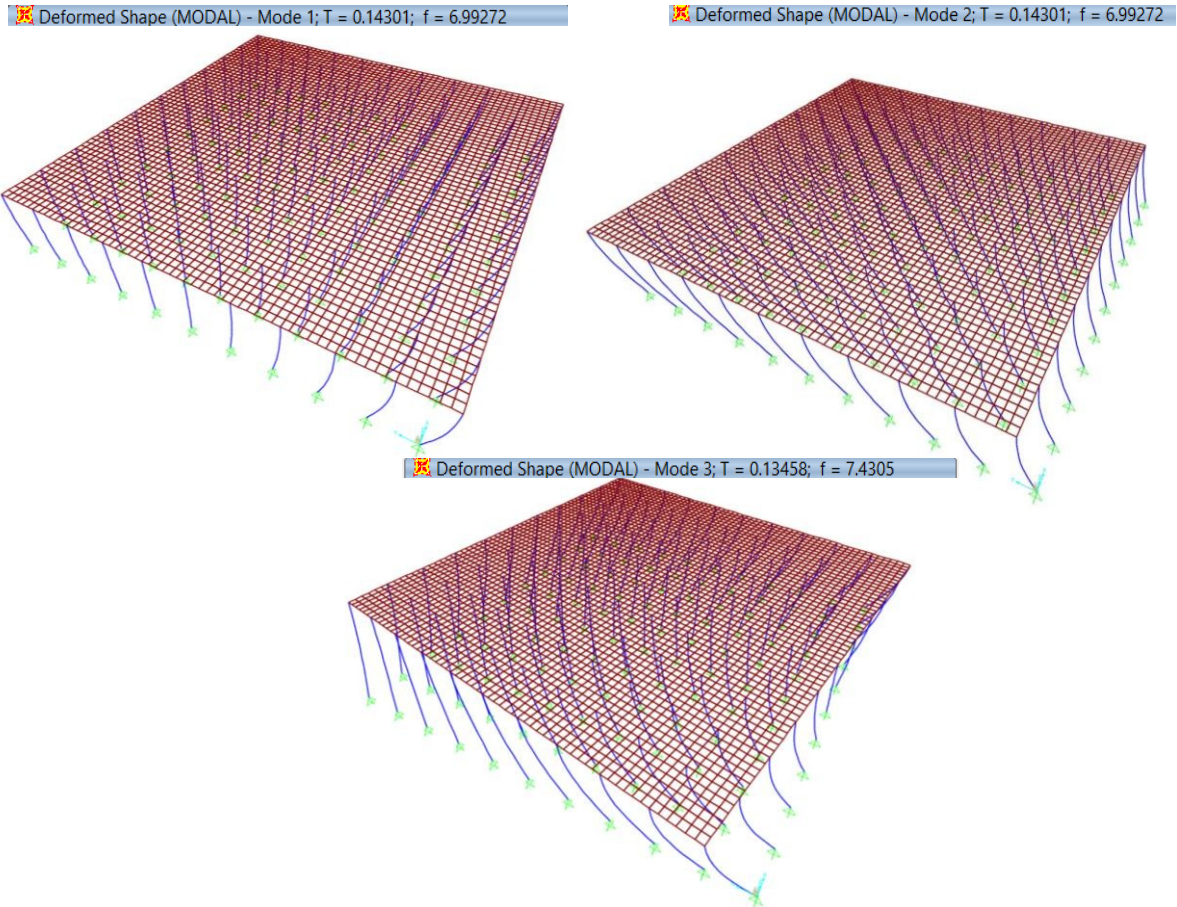
Figure 5: Analytic model created for analyzing truck load effects

### 3-b. Structural Analyses

In the first stage, only first three vibration modes were examined for each configuration to make a modal analysis using the self-weight of the system ignoring live loads that would act on the slab as additional loads. Since the system is symmetrical, assuming the  $T_{1x}$  and  $T_{2y}$  periods are the first two translational periods that have the same duration and  $T_{3\theta}$  is the third period in the torsion mode, periods calculated for each configuration are given in Table 1 and visual explanations of the sample modal behavior for C25 concrete with  $H=150\text{cm}$  height and  $t=10\text{cm}$  slab thickness are given in Figure 6.

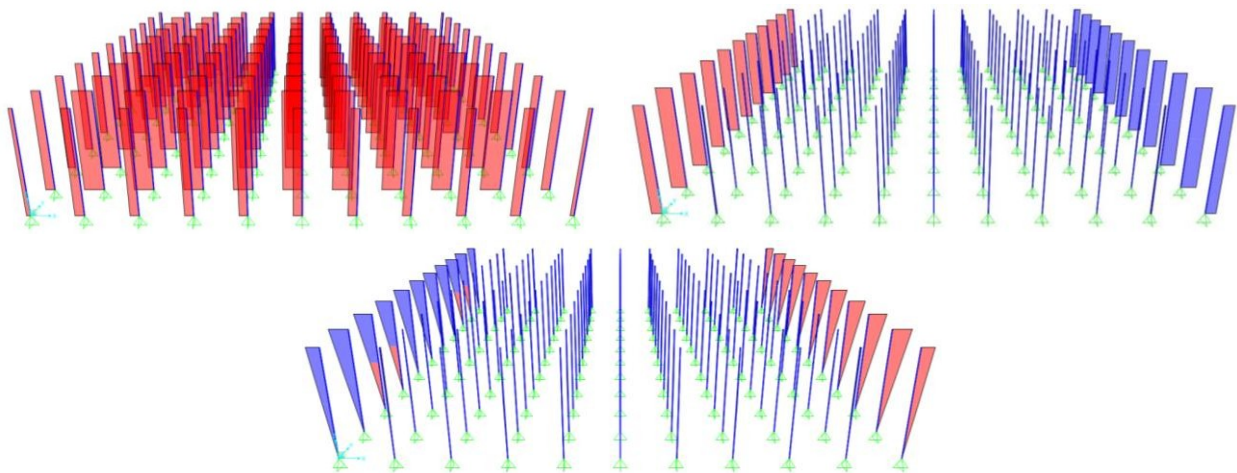
Table 1: First Three Vibration Periods of Analytic Models

|                   |  | Concrete Class C25 |        |        |         |        |        |         |        |        |         |        |        |
|-------------------|--|--------------------|--------|--------|---------|--------|--------|---------|--------|--------|---------|--------|--------|
|                   |  | H=50cm             |        |        | H=100cm |        |        | H=150cm |        |        | H=200cm |        |        |
|                   |  | t=5cm              | t=10cm | t=15cm | t=5cm   | t=10cm | t=15cm | t=5cm   | t=10cm | t=15cm | t=5cm   | t=10cm | t=15cm |
| <b>T1, T2 (s)</b> |  | 0.033              | 0.029  | 0.032  | 0.081   | 0.078  | 0.088  | 0.141   | 0.143  | 0.164  | 0.214   | 0.223  | 0.256  |
| <b>T3 (s)</b>     |  | 0.033              | 0.027  | 0.029  | 0.080   | 0.073  | 0.082  | 0.140   | 0.135  | 0.152  | 0.212   | 0.210  | 0.238  |
|                   |  | Concrete Class C30 |        |        |         |        |        |         |        |        |         |        |        |
| <b>T1, T2 (s)</b> |  | 0.033              | 0.028  | 0.032  | 0.079   | 0.077  | 0.088  | 0.139   | 0.143  | 0.164  | 0.212   | 0.223  | 0.256  |
| <b>T3 (s)</b>     |  | 0.033              | 0.027  | 0.029  | 0.078   | 0.073  | 0.082  | 0.137   | 0.134  | 0.152  | 0.209   | 0.210  | 0.238  |



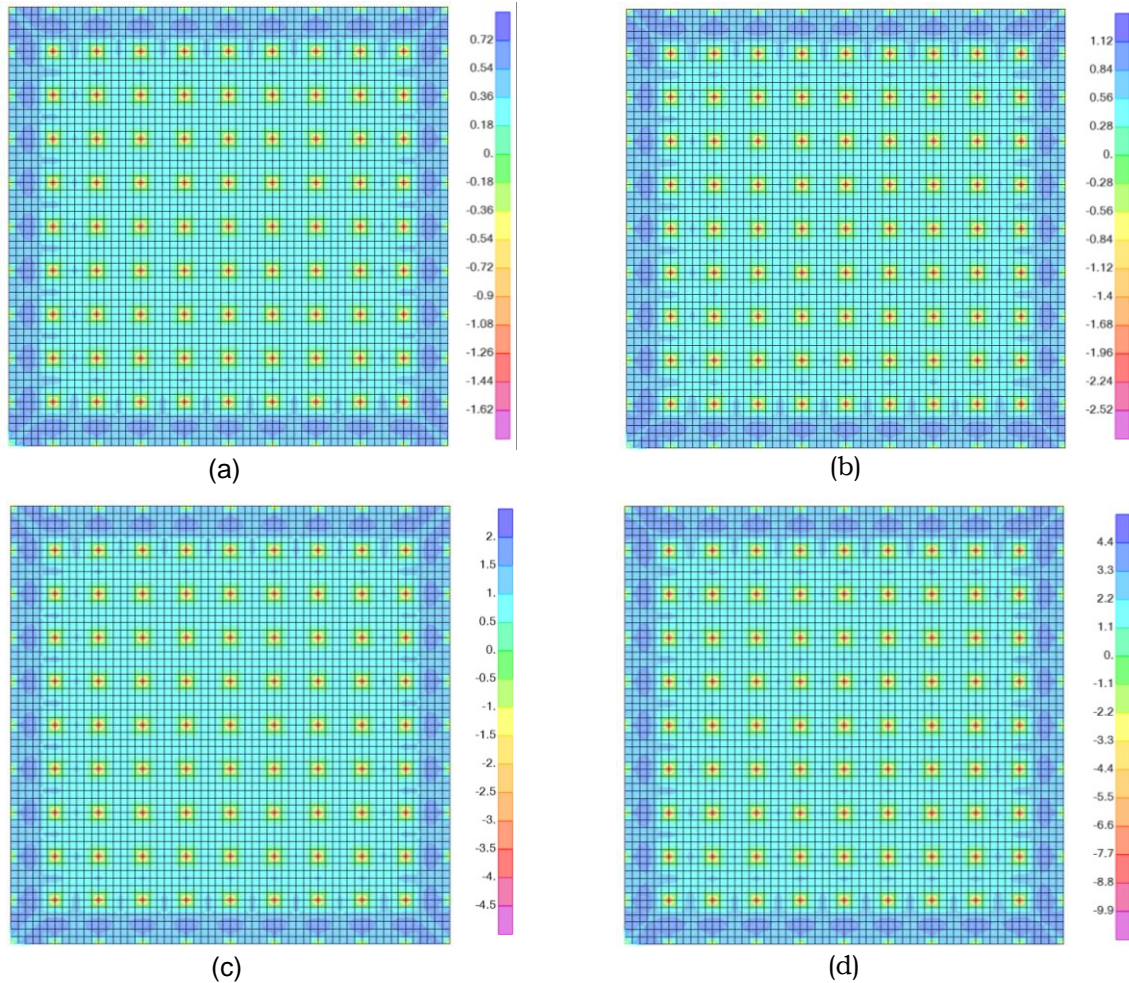
**Figure 6:** First three modes of the sample system

In the second phase of the analysis, internal forces occurring in the slabs and columns arising from uniformly distributed live loads acting on the raised floors were calculated separately for each configuration considering the design loads. Column internal forces in the case that a live load of  $q=20 \text{ kN/m}^2$  is acting on the sample system are given in Figure 7.



**Figure 7:** Internal forces in the columns of the sample system under  $p=37.88 \text{ kN/m}^2$  design load: axial force  $N_a$  (top-left), shear force  $V_a$  (top-right) and bending moment  $M_a$  (bottom)

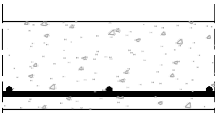
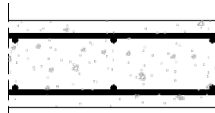
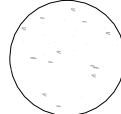
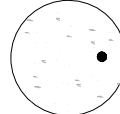

Alterations in the bending moments occurring in the slabs of the same sample system under the effect of  $q=5 \text{ kN/m}^2$  (a);  $q=10 \text{ kN/m}^2$  (b);  $q=20 \text{ kN/m}^2$  (c) ve  $q=50 \text{ kN/m}^2$  (d) live loads are given in Figure 8.



**Figure 8:** Bending moments in the slabs of the sample system under various live loads

After similar analyses have been completed for all of the alternative systems, reinforced concrete sections were designed. Alternative reinforcing steel bars to be used in the application and their layouts are summarized in Table 2.

**Table 2:** Frequently Preferred Reinforcement Layout Alternatives for System Members

|               |   |   |   |
|---------------|---|---|---|
| <b>Slab</b>   |  |  |   |
|               | <b>Q188/188 or Q335/335</b>   | <b>2xQ188/188 or 2xQ335/335</b>   |   |
| <b>Column</b> |  |  |  |
|               | <b>Without rebar</b>  | <b>Ø8 or Ø10</b>  | <b>2Ø8 or 2Ø10</b>  |



Structural analyses and capacities of the components are studied comprehensively for the system configurations given in Table 1 and various rebar layouts summarized in Table 2. Required reinforcement areas in slabs for the sample system presented above are given in Figure 9 for  $q=5\sim 50 \text{ kN/m}^2$  live loads; bearing capacities are shown in Figure 10 assuming the amount of rebar in the columns is **2Ø10**.

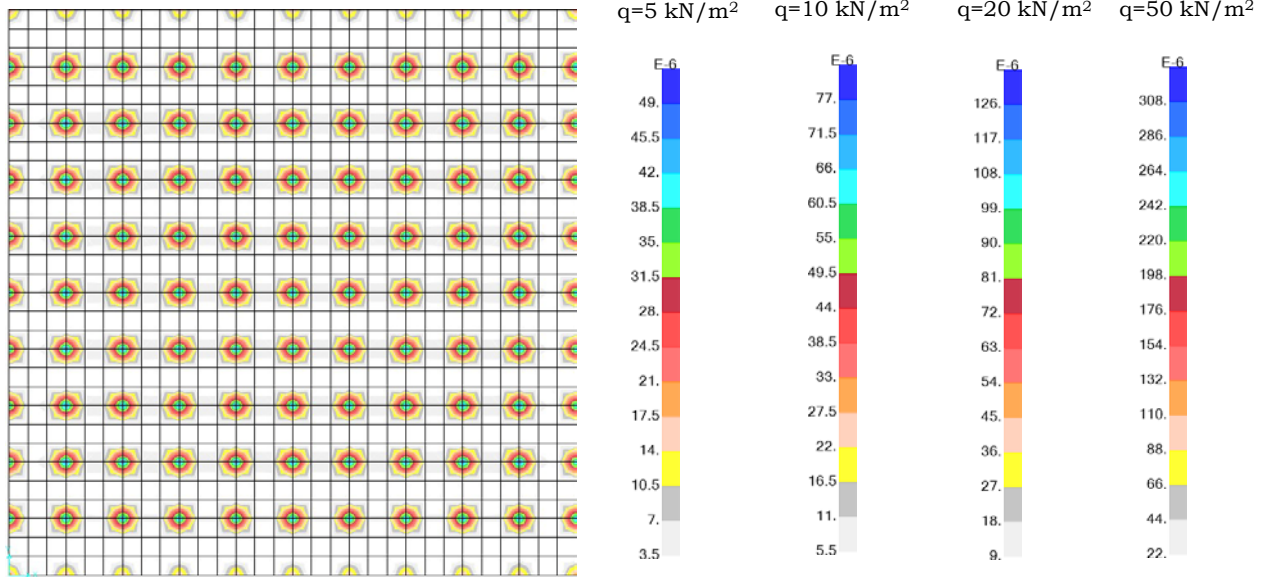


Figure 9: Required reinforcement areas under various live loads ( $\text{mm}^2$ )

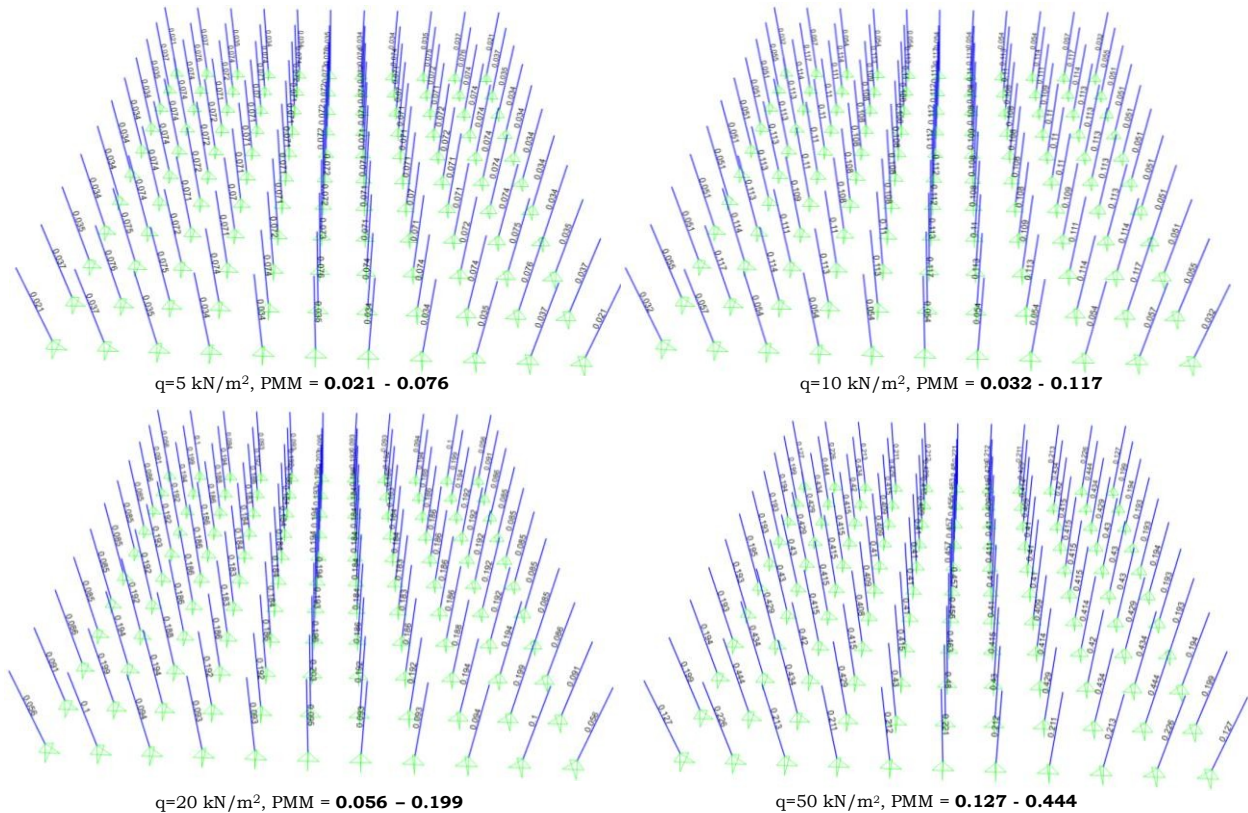
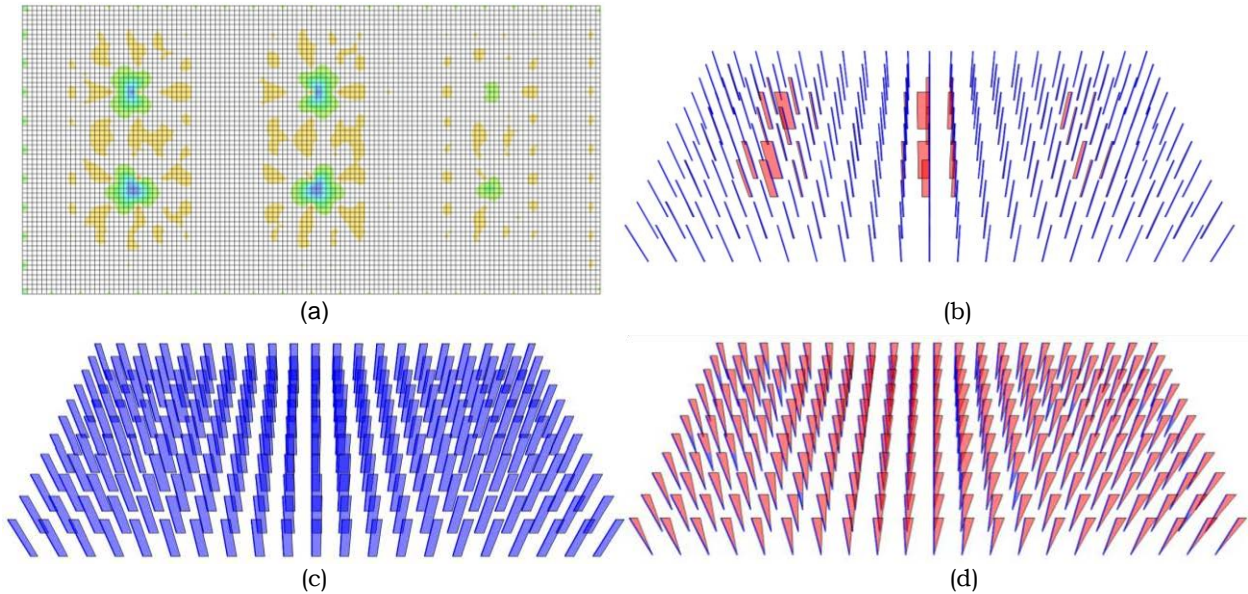


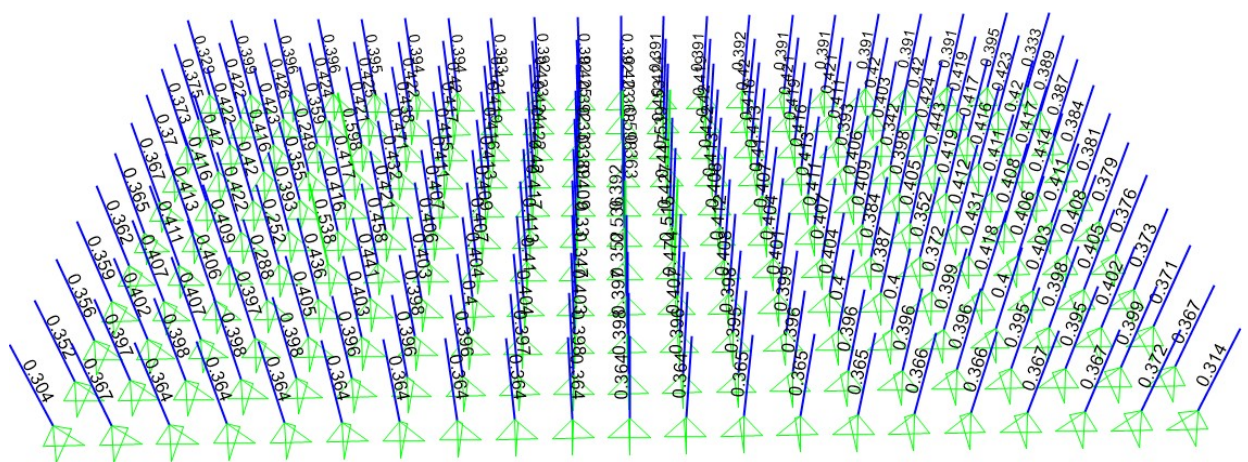
Figure 10: Column capacity values for the sample system under various live loads

After repeating similar analyses for all the system configurations and alternative rebar layouts, analyses were carried out using the model created for truck load. Maximum slab bending moments (a), column axial forces (b), shear forces (c) and bending moments (d) arising from the p design loads occurring on the system in the analytic model in Figure 5 are presented in Figure 11.

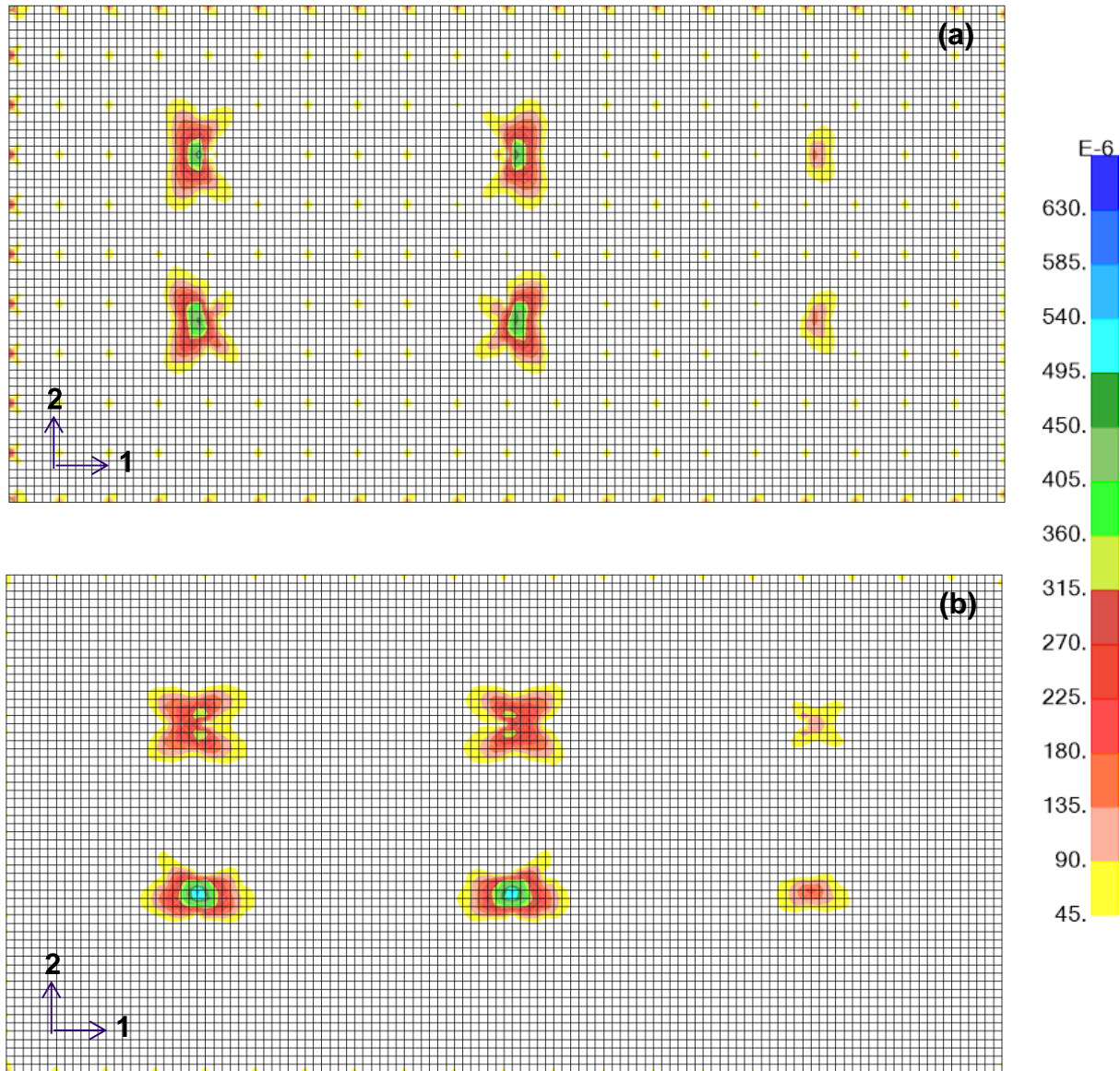


**Figure 11:** Internal forces in the sample system calculated under the truck load effect

Taking the live truck load for each system configuration into account, the number of reinforcing bars in the slabs and columns of the system were determined. Figure 12 shows the capacity rates in the case that 2Ø10 rebars are used in the columns of the sample system that are exposed to skew bending in both directions; Figure 13 shows the required reinforcement areas for the slabs of the sample system in 1-1 (a) and 2-2 (b) axis.



**Figure 12:** Capacity values of the columns with 2Ø10 reinforcing steel bars under the truck load effect (oblique bending)



**Figure 13:** Required reinforcement areas in both directions under the truck load

### 3-c. Structural Design in Accordance with the Regulations

For alternative applications, the number of minimum and maximum tension reinforcing bars and internal forces of the rebars that are frequently used are examined in accordance with TS-500. For rebar alternatives, along with the rebar layout summarized in Table 2, usage of thicker Q377/377 and Q524/524 wire meshes in case of higher live loads and system assembly height was discussed additionally. Thickness of the slab was taken  $d'=15\text{mm}$ . Table 3 demonstrates the features of the slabs realized with ABS Plus Disposable Formwork System and maximum bearable additional loads **independently from the system height H** while Table 4 demonstrates the capacities of the columns in the system.

**Table 3:** Design Alternatives and Capacities of the Slabs

|   |                 | SLAB CHARACTERISTICS |        |         |         |         |         |
|---|-----------------|----------------------|--------|---------|---------|---------|---------|
|   |                 | t=5cm                |        | t=10cm  |         | t=15cm  |         |
|   |                 | C25                  | C30    | C25     | C30     | C25     | C30     |
| mm <sup>2</sup> /m  | As,x≈As,y (min) | 61.25                | 61.25  | 148.75  | 148.75  | 236.25  | 236.25  |
|   | As,x≈As,y (max) | 444.44               | 523.16 | 1079.42 | 1270.57 | 1714.39 | 2017.97 |
| Bearable Moment<br>Mr (kNm/m)                             | Q188/188        | 2.63                 | 2.66   | 6.71    | 6.75    | <Asmin  | <Asmin  |
|   | 2□Q188/188      | ..*                  | ..*    | 7.06    | 7.24    | <Asmin  | <Asmin  |
|   | Q335/335        | 4.35                 | 4.47   | 11.63   | 11.76   | 18.91   | 19.04   |
|   | 2□Q335/335      | ..*                  | ..*    | 11.71   | 11.94   | 18.99   | 19.22   |
|   | Q377/377        | 4.79                 | 4.95   | 12.98   | 13.14   | 21.18   | 21.34   |
|   | 2□Q377/377      | ..*                  | ..*    | 13.01   | 13.26   | 21.21   | 21.45   |
|   | Q524/524        | >Asmax               | >Asmax | 17.53   | 17.84   | 28.92   | 29.23   |
|   | 2□Q524/524      | ..*                  | ..*    | 17.54   | 17.82   | 28.93   | 29.21   |
| Allowable Additional<br>Load<br>Qmax (kN/m <sup>2</sup> ) | Q188/188        | 29.0                 | 29.4   | 79.6    | 80.1    | --      | --      |
|   | 2□Q188/188      | --                   | --     | 83.9    | 86.2    | --      | --      |
|   | Q335/335        | 50.4                 | 51.8   | 140.6   | 142.2   | 230.8   | 232.5   |
|   | 2□Q335/335      | --                   | --     | 141.6   | 144.4   | 231.9   | 234.7   |
|   | Q377/377        | 55.8                 | 57.8   | 157.3   | 159.3   | 259.0   | 261.0   |
|   | 2□Q377/377      | --                   | --     | 157.7   | 160.8   | 259.4   | 262.4   |
|   | Q524/524        | --                   | --     | 213.8   | 217.6   | 354.9   | 358.8   |
|   | 2□Q524/524      | --                   | --     | 213.9   | 217.3   | 355.1   | 358.6   |

For the slabs with a thickness of t=5 cm, double-curtain reinforcement layout is not applicable.

**Table 4:** Rebar Alternatives for Columns and Absolute Axial Load Bearing Capacities

|          |           | C25      |                           |        |        | C30      |                           |        |        |
|----------|-----------|----------|---------------------------|--------|--------|----------|---------------------------|--------|--------|
|          |           | Nr (kN)* | Qmax (kN/m <sup>2</sup> ) |        |        | Nr (kN)* | Qmax (kN/m <sup>2</sup> ) |        |        |
|          |           |          | t=5cm                     | t=10cm | t=15cm |          | t=5cm                     | t=10cm | t=15cm |
| H=50cm   | w/o Rebar | 177.33   |                           |        |        | 208.62   |                           |        |        |
|          | Ø8        | 184.08   | 98                        | 98     | 102    | 220.89   | 98                        | 98     | 102    |
|          | 2xØ8      | 184.08   | 104                       | 104    | 108    | 220.89   | 104                       | 104    | 108    |
|          | Ø10       | 184.08   | 98                        | 98     | 102    | 220.89   | 98                        | 98     | 102    |
|          | 2xØ10     | 184.08   | 106                       | 106    | 110    | 220.89   | 106                       | 106    | 110    |
| H=100cm  | Ø8        | 184.08   | 96                        | 98     | 98     | 220.89   | 96                        | 98     | 98     |
|          | 2xØ8      | 184.08   | 100                       | 102    | 104    | 220.89   | 100                       | 102    | 104    |
|          | Ø10       | 184.08   | 96                        | 98     | 98     | 220.89   | 96                        | 98     | 98     |
|          | 2xØ10     | 184.08   | 102                       | 104    | 104    | 220.89   | 102                       | 104    | 104    |
| H=150 cm | Ø8        | 184.08   | 86                        | 86     | 86     | 220.89   | 86                        | 86     | 86     |
|          | 2xØ8      | 184.08   | 90                        | 92     | 92     | 220.89   | 90                        | 92     | 92     |
|          | Ø10       | 184.08   | 86                        | 86     | 86     | 220.89   | 86                        | 86     | 86     |
|          | 2xØ10     | 184.08   | 90                        | 92     | 92     | 220.89   | 90                        | 92     | 92     |
| H=200cm  | Ø8        | 184.08   | 76                        | 76     | 76     | 220.89   | 76                        | 76     | 76     |
|          | 2xØ8      | 184.08   | 78                        | 78     | 76     | 220.89   | 78                        | 78     | 76     |
|          | Ø10       | 184.08   | 76                        | 76     | 76     | 220.89   | 76                        | 76     | 76     |
|          | 2xØ10     | 184.08   | 78                        | 78     | 76     | 220.89   | 78                        | 78     | 76     |

In accordance with TS-500, axial load is limited with  $0.60f_{ck}$  to prevent brittle collapse

The tables show that the concrete class C25 or C30 affects the bending moment capacities in a negligible amount. Due to the upper limit applied to prevent brittle collapse, it does not have an effect on the column bearing capacities.

It can be seen that for the slabs with **t=5 cm** thickness, it is the bending effect and reinforcement plan that determine the bearable loads by the system; for the slabs with **t=10 cm** thickness, slab and system height and reinforcement plan of the column and for the slabs with **t=15 cm** thickness, the determinative parameter is the system height and reinforcement plan of the column.

As a result of evaluating the slabs and columns together, maximum safety loads summarized in Table 5 should not be exceeded for various configurations. The use of C25 or C30 concrete has been investigated jointly.

**Table 5:** Maximum Allowable Loads for ABS Plus Disposable Formwork System

|        |     | Maximum Allowable Live Load- $q_{max}$ (kN/m <sup>2</sup> ) |           |                    |          |          |          |          |            |          |            |          |            |          |            |          |            |          |            |          |            |     |     |
|--------|-----|---|-----------|--------------------|----------|----------|----------|----------|------------|----------|------------|----------|------------|----------|------------|----------|------------|----------|------------|----------|------------|-----|-----|
| H (cm) | 200 | Column Reinforcement  | 2Ø10      | 29                 | 50       | 55       | 78       | 78       | 78         | 78       | 78         | 78       | 78         | 78       | 78         | 78       | 76         | 76       | 76         | 76       | 76         | 76  |     |
|        |     |   | 2Ø8       | 29                 | 50       | 55       | 78       | 78       | 78         | 78       | 78         | 78       | 78         | 78       | 78         | 78       | 78         | 76       | 76         | 76       | 76         | 76  | 76  |
|        |     |   | Ø10       | 29                 | 50       | 55       | 76       | 76       | 76         | 76       | 76         | 76       | 76         | 76       | 76         | 76       | 76         | 76       | 76         | 76       | 76         | 76  | 76  |
|        |     |   | Ø8        | 29                 | 50       | 55       | 76       | 76       | 76         | 76       | 76         | 76       | 76         | 76       | 76         | 76       | 76         | 76       | 76         | 76       | 76         | 76  | 76  |
|        | 150 |   | 2Ø10      | 29                 | 50       | 55       | 79       | 83       | 92         | 92       | 92         | 92       | 92         | 92       | 92         | 92       | 92         | 92       | 92         | 92       | 92         | 92  | 92  |
|        |     |   | 2Ø8       | 29                 | 50       | 55       | 79       | 83       | 92         | 92       | 92         | 92       | 92         | 92       | 92         | 92       | 92         | 92       | 92         | 92       | 92         | 92  | 92  |
|        |     |   | Ø10       | 29                 | 50       | 55       | 79       | 83       | 86         | 86       | 86         | 86       | 86         | 86       | 86         | 86       | 86         | 86       | 86         | 86       | 86         | 86  | 86  |
|        |     |   | Ø8        | 29                 | 50       | 55       | 79       | 83       | 86         | 86       | 86         | 86       | 86         | 86       | 86         | 86       | 86         | 86       | 86         | 86       | 86         | 86  | 86  |
|        | 100 |   | 2Ø10      | 29                 | 50       | 55       | 79       | 83       | 104        | 104      | 104        | 104      | 104        | 104      | 104        | 104      | 104        | 104      | 104        | 104      | 104        | 104 | 104 |
|        |     |   | 2Ø8       | 29                 | 50       | 55       | 79       | 83       | 102        | 102      | 102        | 102      | 102        | 102      | 102        | 102      | 102        | 104      | 104        | 104      | 104        | 104 | 104 |
|        |     |   | Ø10       | 29                 | 50       | 55       | 79       | 83       | 98         | 98       | 98         | 98       | 98         | 98       | 98         | 98       | 98         | 98       | 98         | 98       | 98         | 98  | 98  |
|        |     |   | Ø8        | 29                 | 50       | 55       | 79       | 83       | 98         | 98       | 98         | 98       | 98         | 98       | 98         | 98       | 98         | 98       | 98         | 98       | 98         | 98  | 98  |
|        | 50  |   | 2Ø10      | 29                 | 50       | 55       | 79       | 83       | 106        | 106      | 106        | 106      | 106        | 106      | 106        | 106      | 106        | 110      | 110        | 110      | 110        | 110 | 110 |
|        |     |   | 2Ø8       | 29                 | 50       | 55       | 79       | 83       | 104        | 104      | 104        | 104      | 104        | 104      | 104        | 104      | 104        | 108      | 108        | 108      | 108        | 108 | 108 |
|        |     |   | Ø10       | 29                 | 50       | 55       | 79       | 83       | 98         | 98       | 98         | 98       | 98         | 98       | 98         | 98       | 98         | 102      | 102        | 102      | 102        | 102 | 102 |
|        |     |   | Ø8        | 29                 | 50       | 55       | 79       | 83       | 98         | 98       | 98         | 98       | 98         | 98       | 98         | 98       | 98         | 102      | 102        | 102      | 102        | 102 | 102 |
|        |     |   | w/o rebar | 20                 | 20       | 20       | 20       | 20       | 20         | 20       | 20         | 20       | 20         | 20       | 20         | 20       | 20         | 20       | 20         | 20       | 20         | 20  | 20  |
|        |     |   |           | Slab Reinforcement | Q188/188 | Q335/335 | Q377/377 | Q188/188 | 2xQ188/188 | Q335/335 | 2xQ335/335 | Q377/377 | 2xQ377/377 | Q524/524 | 2xQ524/524 | Q335/335 | 2xQ335/335 | Q377/377 | 2xQ377/377 | Q524/524 | 2xQ524/524 |     |     |
|        |     |   |           | t (cm)             | 5        |          |          | 10       |            |          |            |          |            | 15       |            |          |            |          |            |          |            |     |     |

Applies to both C25 and C30 concrete classes.

Rebar plan to be used in different system configurations considering the standard loads for ABS Plus Disposable Formwork System is given at the end of this report as APPENDIX-1.

## 4. CONCLUSION and ADVICES

Plastic disposable formwork application of ABS Plus Disposable Formwork System which was developed by ABS Building Materials as a domestic production has been analyzed analytically considering different loading, reinforcement layout and height configurations. Assessments involve the **reinforced concrete bearing system characteristics** that will be built using the formwork system but they do not involve the attributions of the plastic material.

As a result of the analyses done, following results have been found:

- For a system height above 50cm ( $H > 50$  cm), application without rebar is not recommended. In case the height  $H$  is 50 cm and columns are used without reinforcing bars, maximum bearable live load should be restricted with 20 kN/m<sup>2</sup> independently of the slab thickness and slab reinforcement.
- For a slab thickness  $t=5$  cm, double-curtain reinforcement layout is not recommended. For single-line wire mesh alternatives, allowable additional loads may vary between 20~55 kN/m<sup>2</sup> depending on the system height and column reinforcement.
- For a slab thickness equal to or above 10 cm ( $t \geq 10$ cm), double-curtain reinforcement layout is applicable. Allowable live loads depending on the system height and column reinforcement vary between 76~106 kN/m<sup>2</sup> for  $t=10$ cm and 76~110 kN/m<sup>2</sup> for  $t=15$ cm.

As a consequence, we consider and approve that the application of concrete raised floors to be built with ABS Plus Disposable Formwork System is appropriate from a technical aspect.

Respectfully submitted for your information.

**Assoc. Prof. Dr. Beyza TAŞKIN**

**Asst. Prof. Dr. Burcu GÜNEŞ**

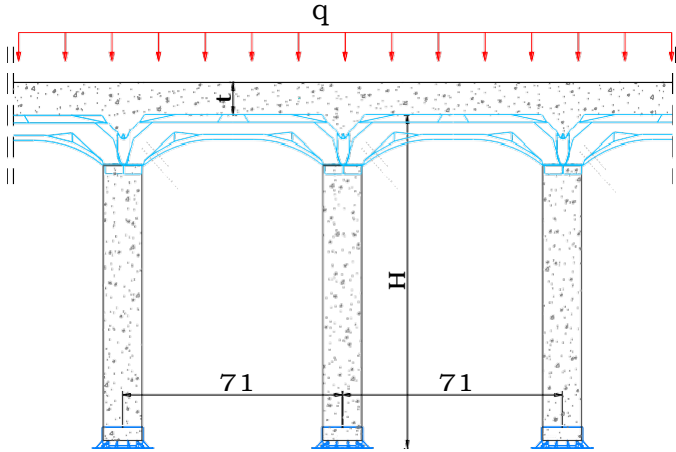
**June, 2018**

ITU CIVIL ENGINEERING FACULTY DEANERY



# APPENDIX -2

## ENGLISH VERSIONS OF DESIGN TABLES & SYSTEM PROPERTIES



| H (cm) | t (cm) | q (kN/m <sup>2</sup> ) |
|--------|--------|------------------------|
| 50     | 5      | 5                      |
| 100    | 10     | 10                     |
| 150    | 15     | 20                     |
| 200    |        | 50                     |
|        |        | H20-S16*               |
| Rebars |        | Wire Mesh Bars         |
| -      |        | Q188/188 2×Q188/188    |
| φ8     |        | Q335/335 2×Q335/335    |
| 2φ8    |        |                        |
| φ10    |        |                        |
| 2φ10   |        |                        |

\* For H20-S16-44 truckload, 40 kN for the front wheels and 160 kN for middle and rear wheels are considered. The braking force is taken as 25% of the axle weights.

Fig. 2E: System configurations and numerical values of the characteristic parameters

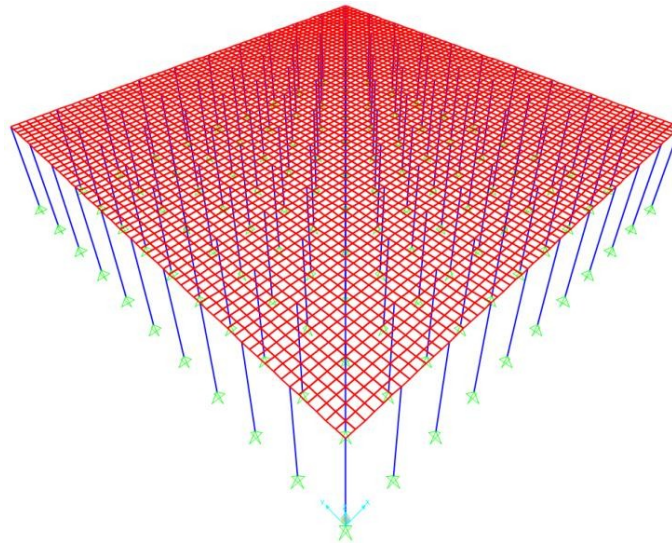


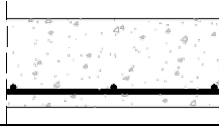
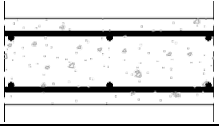
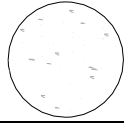
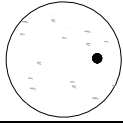
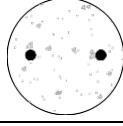
Fig. 4E: SAP2000 computer program model for “ABS Plus Disposable Formwork System”

Table 1E: First Three Vibration Modes of the Analytical Models

| Concrete Class C25 |       |        |         |       |        |         |       |        |         |       |        |        |
|--------------------|-------|--------|---------|-------|--------|---------|-------|--------|---------|-------|--------|--------|
| H=50cm             |       |        | H=100cm |       |        | H=150cm |       |        | H=200cm |       |        |        |
|                    | t=5cm | t=10cm | t=15cm  | t=5cm | t=10cm | t=15cm  | t=5cm | t=10cm | t=15cm  | t=5cm | t=10cm | t=15cm |
| T1, T2 (s)         | 0.033 | 0.029  | 0.032   | 0.081 | 0.078  | 0.088   | 0.141 | 0.143  | 0.164   | 0.214 | 0.223  | 0.256  |
| T3 (s)             | 0.033 | 0.027  | 0.029   | 0.080 | 0.073  | 0.082   | 0.140 | 0.135  | 0.152   | 0.212 | 0.210  | 0.238  |
| Concrete Class C30 |       |        |         |       |        |         |       |        |         |       |        |        |
| T1, T2 (s)         | 0.033 | 0.028  | 0.032   | 0.079 | 0.077  | 0.088   | 0.139 | 0.143  | 0.164   | 0.212 | 0.223  | 0.256  |
| T3 (s)             | 0.033 | 0.027  | 0.029   | 0.078 | 0.073  | 0.082   | 0.137 | 0.134  | 0.152   | 0.209 | 0.210  | 0.238  |



**Table 2E:** Frequently Preferred Reinforcement Alternatives for System Members

|      |   |   |   |
|------|---|---|---|
| Slab |  |  |   |
|      | <b>Q188/188 or Q335/335</b>   | <b>2□Q188/188 or 2□Q335/335</b>   |   |
| Pier |  |  |  |
|      | <b>Without Reinforcement</b>  | <b>Ø8 or Ø10</b>  | <b>2Ø8 or 2Ø10</b>  |

**Table 3E:** Design Alternatives for Slabs and Their Capacities

|   |                        | SLAB CHARACTERISTICS |                  |         |         |                  |                  |
|---|------------------------|----------------------|------------------|---------|---------|------------------|------------------|
|   |                        | t=5cm                |                  | t=10cm  |         | t=15cm           |                  |
|   |                        | C25                  | C30              | C25     | C30     | C25              | C30              |
| mm <sup>2</sup> /m  | <b>As,x≈As,y (min)</b> | 61.25                | 61.25            | 148.75  | 148.75  | 236.25           | 236.25           |
|   | <b>As,x≈As,y (max)</b> | 444.44               | 523.16           | 1079.42 | 1270.57 | 1714.39          | 2017.97          |
| Bearable Moment<br><b>Mr (kNm/m)</b>                        | Q188/188               | 2.63                 | 2.66             | 6.71    | 6.75    | <b>&lt;Asmin</b> | <b>&lt;Asmin</b> |
|   | 2□Q188/188             | --*                  | --*              | 7.06    | 7.24    | <b>&lt;Asmin</b> | <b>&lt;Asmin</b> |
|   | Q335/335               | 4.35                 | 4.47             | 11.63   | 11.76   | 18.91            | 19.04            |
|   | 2□Q335/335             | --*                  | --*              | 11.71   | 11.94   | 18.99            | 19.22            |
|   | Q377/377               | 4.79                 | 4.95             | 12.98   | 13.14   | 21.18            | 21.34            |
|   | 2□Q377/377             | --*                  | --*              | 13.01   | 13.26   | 21.21            | 21.45            |
|   | Q524/524               | <b>&gt;Asmax</b>     | <b>&gt;Asmax</b> | 17.53   | 17.84   | 28.92            | 29.23            |
|   | 2□Q524/524             | --*                  | --*              | 17.54   | 17.82   | 28.93            | 29.21            |
| Allowable Additional Load<br><b>Qmax (kN/m<sup>2</sup>)</b> | Q188/188               | 29.0                 | 29.4             | 79.6    | 80.1    | --               | --               |
|   | 2□Q188/188             | --                   | --               | 83.9    | 86.2    | --               | --               |
|   | Q335/335               | 50.4                 | 51.8             | 140.6   | 142.2   | 230.8            | 232.5            |
|   | 2□Q335/335             | --                   | --               | 141.6   | 144.4   | 231.9            | 234.7            |
|   | Q377/377               | 55.8                 | 57.8             | 157.3   | 159.3   | 259.0            | 261.0            |
|   | 2□Q377/377             | --                   | --               | 157.7   | 160.8   | 259.4            | 262.4            |
|   | Q524/524               | --                   | --               | 213.8   | 217.6   | 354.9            | 358.8            |
|   | 2□Q524/524             | --                   | --               | 213.9   | 217.3   | 355.1            | 358.6            |

Double reinforcement is not applicable for the slab thickness of t=5cm

Table 4E: Rebar Alternatives for Columns and Absolute Axial Load Bearing Capacities

|          |           | C25                  |                                       |        |        | C30                  |                                       |        |        |    |
|----------|-----------|----------------------|---------------------------------------|--------|--------|----------------------|---------------------------------------|--------|--------|----|
|          |           | N <sub>r</sub> (kN)* | Q <sub>max</sub> (kN/m <sup>2</sup> ) |        |        | N <sub>r</sub> (kN)* | Q <sub>max</sub> (kN/m <sup>2</sup> ) |        |        |    |
|          |           |                      | t=5cm                                 | t=10cm | t=15cm |                      | t=5cm                                 | t=10cm | t=15cm |    |
| H=50cm   | w/o Rebar | 177.33               |                                       |        |        | 208.62               |                                       |        |        |    |
|          | Ø8        | 184.08               | 98                                    | 98     | 102    | 220.89               | 98                                    | 98     | 102    |    |
|          | 2xØ8      | 184.08               | 104                                   | 104    | 108    | 220.89               | 104                                   | 104    | 108    |    |
|          | Ø10       | 184.08               | 98                                    | 98     | 102    | 220.89               | 98                                    | 98     | 102    |    |
| H=100cm  | 2xØ10     | 184.08               | 106                                   | 106    | 110    | 220.89               | 106                                   | 106    | 110    |    |
|          | Ø8        | 184.08               | 96                                    | 98     | 98     | 220.89               | 96                                    | 98     | 98     |    |
|          | 2xØ8      | 184.08               | 100                                   | 102    | 104    | 220.89               | 100                                   | 102    | 104    |    |
|          | Ø10       | 184.08               | 96                                    | 98     | 98     | 220.89               | 96                                    | 98     | 98     |    |
| H=150 cm | 2xØ10     | 184.08               | 102                                   | 104    | 104    | 220.89               | 102                                   | 104    | 104    |    |
|          | Ø8        | 184.08               | 86                                    | 86     | 86     | 220.89               | 86                                    | 86     | 86     |    |
|          | 2xØ8      | 184.08               | 90                                    | 92     | 92     | 220.89               | 90                                    | 92     | 92     |    |
|          | Ø10       | 184.08               | 86                                    | 86     | 86     | 220.89               | 86                                    | 86     | 86     |    |
| H=200cm  | 2xØ10     | 184.08               | 90                                    | 92     | 92     | 220.89               | 90                                    | 92     | 92     |    |
|          | Ø8        | 184.08               | 76                                    | 76     | 76     | 220.89               | 76                                    | 76     | 76     |    |
|          | 2xØ8      | 184.08               | 78                                    | 78     | 76     | 220.89               | 78                                    | 78     | 76     |    |
|          | Ø10       | 184.08               | 76                                    | 76     | 76     | 220.89               | 76                                    | 76     | 76     |    |
|          |           | 2xØ10                | 184.08                                | 78     | 78     | 76                   | 220.89                                | 78     | 78     | 76 |

To prevent brittle collapse, axial force is limited by 0.60f<sub>ck</sub> according to TS-500 code.

Table 5E: Maximum Allowable Loads for ABS Plus Disposable Formwork System

| Maximum Allowable Live Load- q <sub>max</sub> (kN/m <sup>2</sup> ) |     |                      |                    |          |          |          |          |            |          |            |          |            |          |            |          |            |          |            |          |            |
|--|-----|----------------------|--------------------|----------|----------|----------|----------|------------|----------|------------|----------|------------|----------|------------|----------|------------|----------|------------|----------|------------|
| H (mm)   | 200 | Column Reinforcement | 2Ø10               | 29       | 50       | 55       | 78       | 78         | 78       | 78         | 78       | 78         | 78       | 76         | 76       | 76         | 76       | 76         |          |            |
|  |     |                      | 2Ø8                | 29       | 50       | 55       | 78       | 78         | 78       | 78         | 78       | 78         | 78       | 78         | 76       | 76         | 76       | 76         | 76       |            |
|  |     |                      | Ø10                | 29       | 50       | 55       | 76       | 76         | 76       | 76         | 76       | 76         | 76       | 76         | 76       | 76         | 76       | 76         | 76       |            |
|  |     |                      | Ø8                 | 29       | 50       | 55       | 76       | 76         | 76       | 76         | 76       | 76         | 76       | 76         | 76       | 76         | 76       | 76         | 76       |            |
|  |     |                      | 150                | 2Ø10     | 29       | 50       | 55       | 79         | 83       | 92         | 92       | 92         | 92       | 92         | 92       | 92         | 92       | 92         | 92       | 92         |
|  |     |                      |                    | 2Ø8      | 29       | 50       | 55       | 79         | 83       | 92         | 92       | 92         | 92       | 92         | 92       | 92         | 92       | 92         | 92       | 92         |
|  |     |                      |                    | Ø10      | 29       | 50       | 55       | 79         | 83       | 86         | 86       | 86         | 86       | 86         | 86       | 86         | 86       | 86         | 86       | 86         |
|  |     |                      |                    | Ø8       | 29       | 50       | 55       | 79         | 83       | 86         | 86       | 86         | 86       | 86         | 86       | 86         | 86       | 86         | 86       | 86         |
|  | 100 | 2Ø10                 | 29                 | 50       | 55       | 79       | 83       | 104        | 104      | 104        | 104      | 104        | 104      | 104        | 104      | 104        | 104      | 104        |          |            |
|  |     | 2Ø8                  | 29                 | 50       | 55       | 79       | 83       | 102        | 102      | 102        | 102      | 102        | 102      | 104        | 104      | 104        | 104      | 104        |          |            |
|  |     | Ø10                  | 29                 | 50       | 55       | 79       | 83       | 98         | 98       | 98         | 98       | 98         | 98       | 98         | 98       | 98         | 98       | 98         |          |            |
|  |     | Ø8                   | 29                 | 50       | 55       | 79       | 83       | 98         | 98       | 98         | 98       | 98         | 98       | 98         | 98       | 98         | 98       | 98         |          |            |
|  | 50  | 2Ø10                 | 29                 | 50       | 55       | 79       | 83       | 106        | 106      | 106        | 106      | 106        | 106      | 110        | 110      | 110        | 110      | 110        |          |            |
|  |     | 2Ø8                  | 29                 | 50       | 55       | 79       | 83       | 104        | 104      | 104        | 104      | 104        | 104      | 108        | 108      | 108        | 108      | 108        |          |            |
|  |     | Ø10                  | 29                 | 50       | 55       | 79       | 83       | 98         | 98       | 98         | 98       | 98         | 98       | 102        | 102      | 102        | 102      | 102        |          |            |
|  |     | Ø8                   | 29                 | 50       | 55       | 79       | 83       | 98         | 98       | 98         | 98       | 98         | 98       | 102        | 102      | 102        | 102      | 102        |          |            |
|  |     | w/o rebar            | 20                 | 20       | 20       | 20       | 20       | 20         | 20       | 20         | 20       | 20         | 20       | 20         | 20       | 20         | 20       | 20         |          |            |
|  |     |                      | Slab Reinforcement | Q188/188 | Q335/335 | Q377/377 | Q188/188 | 2xQ188/188 | Q335/335 | 2xQ335/335 | Q377/377 | 2xQ377/377 | Q524/524 | 2xQ524/524 | Q335/335 | 2xQ335/335 | Q377/377 | 2xQ377/377 | Q524/524 | 2xQ524/524 |
|  |     |                      | t (cm)             | 5        |          |          | 10       |            |          |            |          |            | 15       |            |          |            |          |            |          |            |

Applicable for both C25 and C30 concrete classes

